

UL1332 24AWG
Teflon(FEP) Wire
200 DegreeC
(KEY Feature)

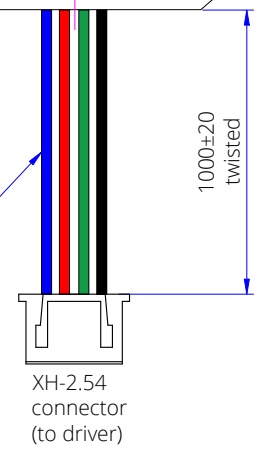

Diagram

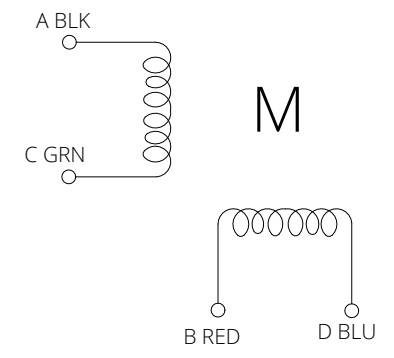

Item	Specification	Item	Specification
Phase Number	2	Step Angle	1.8° ± 5%
Rated Voltage	DC 3.0V / Phase	Rated Current	DC 2.5A / Phase
Phase Resistance	1.2x(1±20%) Ω	Phase Inductance	1.5x(1±20%) mH
Holding Torque	7.5Kgf-cm (75N-cm)	Detent Torque	20 mN-m REF.
Rotate Direction	A-AB-B CW	Insulate Resistance	100Mohm(DC500V)
HI-POT	AC600V/1mA/1S	Insulation Class	Class H 180°C
Rotor Inertia	84.5 g-cm ² REF	Weight	0.55 Kg REF

A		NEW RELEASE		Xu SD	J.B.	9/02/24
REV.	ECN NO.	DESCRIPTION		MADE BY	APPR. BY	DATE
		VIEW	LDO Motors Co., Ltd.			
		SCALE	Part NO. 1.8° NEMA17 Stepper Motor LDO-42STH60-2504AH(S37)			
DRAWN BY	CHECKED BY	APPR. BY	DATE	FACTORY CODE	SHEET NO.	
Xu SD	J.B.	J.B.	10/21/22		1/1	