

## technical data sheet (TDS)

### PP-CF

Eryone PP-CF filament is a material with excellent toughness and strength, suitable for manufacturing impact-resistant and flexible durable structural components, demonstrating good mechanical properties. Additionally, it is a low-density material, making it ideal for lightweight or waterproof models. This filament also possesses outstanding chemical resistance and heat resistance, with a carbon fiber content of 20%.

#### Part one: suggests printing parameters

Parameter	Set up
Nozzle temperature	220-240 °C
Bed temperature	60-80°C
Bed material	glass, PEI, spring steel plate
Bottom printing temperature	220-240 °C
Sealed printing	sealed printing
Printing speed	30-100mm/s
Drying conditions	50~60°C, 8H

#### Part two: Physical Properties of Materials

Property	Testing Method	Unit	Typical Value
Density(g/cm <sup>3</sup> at 21.5 ° C)	ASTM D792 (ISO 1183, GB/T 1033)	g/cm <sup>3</sup>	0.95~1.01
Melt Index(g/10 min)	220 ° C, 10kg 240 ° C, 2.16 kg	g/10min	12-15

## Part three: Mechanical Properties of Printed Samples

Property	Test conditions	Test standards	unit	Typical Value
Tensile strength X-Y	50mm/min	GB/T 1040.4	MPa	50.1
Elastic modulus X-Y	50mm/min	GB/T 1040.1-2006	MPa	1320~1675
Elongation at break X-Y	50mm/min	GB/T 1040.4	%	25~32
Tensile strength X-Z	50mm/min	GB/T 1843	MPa	6~8
Bending strength	2mm/min	GB/T 9341	MPa	16~18
Bending modulus	2mm/min	GB/T 9341	MPa	1672~1935
Charpy Impact strenght	2.75J	GB/T 1043.1-2008	kJ/m2	19.1~22.3

Note: All splines are printed under the following conditions: printing temperature=230 ° C, printing speed=80mm/s, base plate 80 ° C, filling=100%, nozzle diameter=0.4mm

# TENSILE TESTING SPECIMEN

ISO 527,GB/T 1040

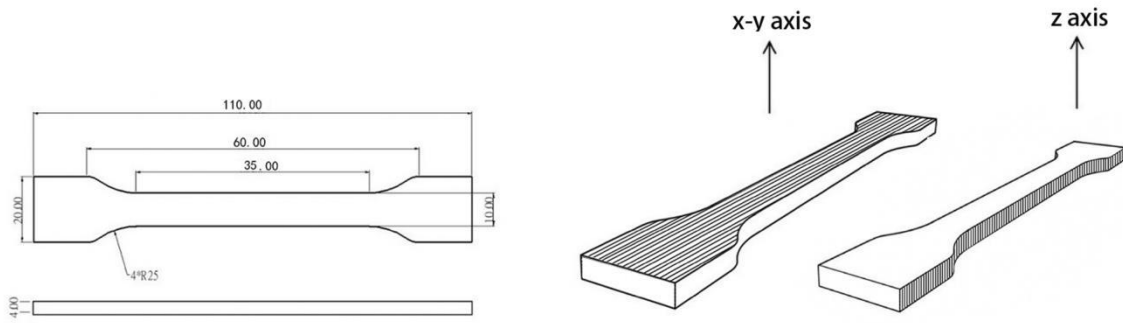

# FLEXURAL TESTING SPECIMEN

ISO 178,GB/T 9341

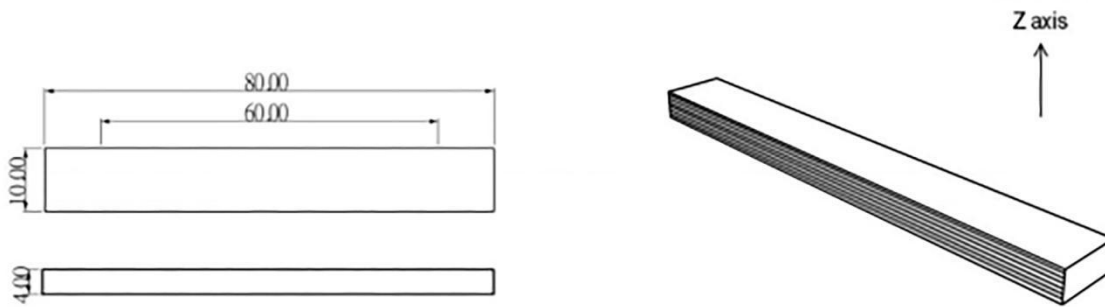

# IMPACT TESTING SPECIMEN

ISO 179,GB/T 1043

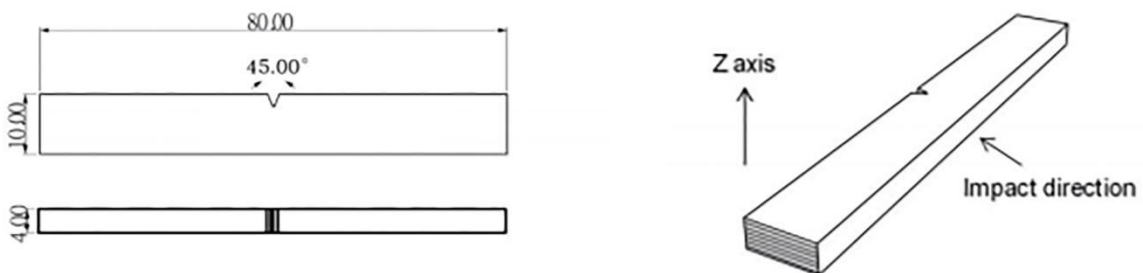

### Disclaimers

The values given in this data table are for reference and comparison only. They should not be used for design specifications or quality control. The actual value may vary depending on the printing conditions. The final performance of printed components depends not only on the material, but also on the component design, environmental conditions, printing conditions, and so on. Product specifications are subject to change without prior notice.