

HT Stepper: (180 °C)

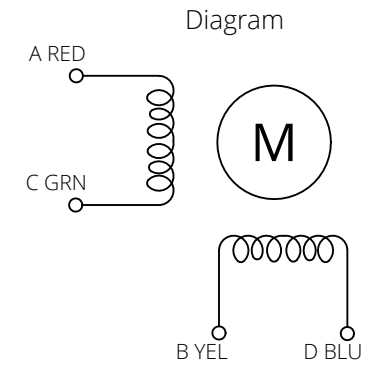
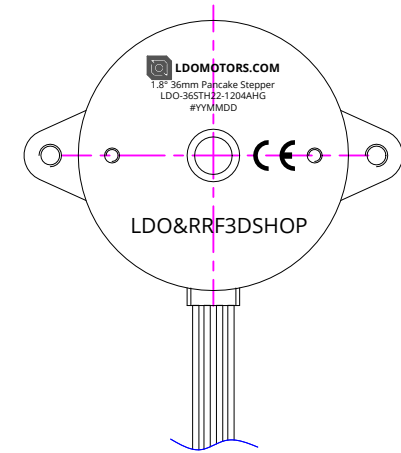
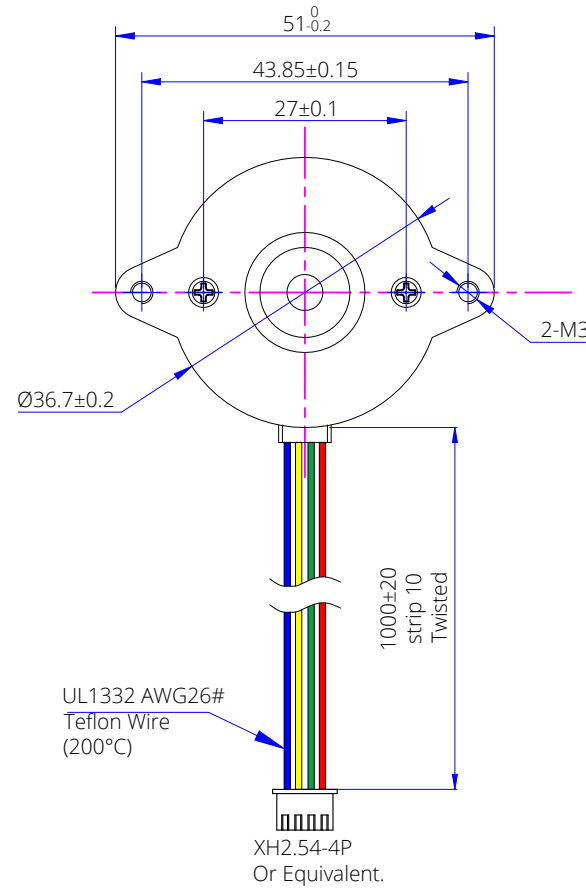
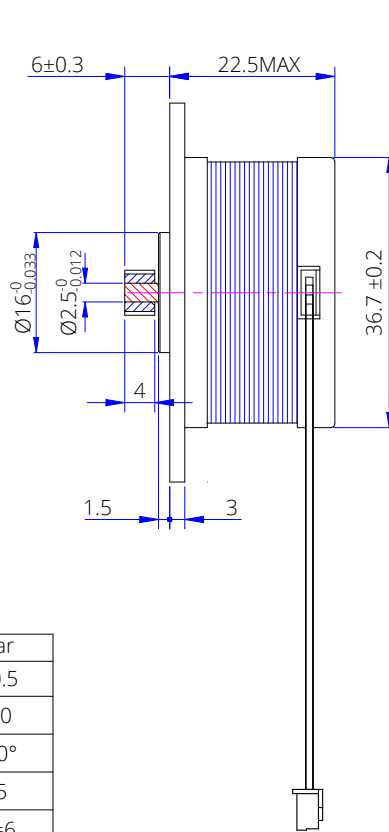

Specification for the gear	
MODULE	m=0.5
NO. OF TEETH	z=10
PRESSURE ANGLE	a=20°
PITCH DIA.	d=5
OUTSIDE DIA.	da=6

Item	Specification	Item	Specification
Phase Number	2	Step Angle	1.8° ± 5%
Rated Voltage	DC 2.88V / Phase	Rated Current	DC 1.2A / Phase
Phase Resistance	2.4x(1±15%) Ω	Phase Inductance	1.8x(1±20%) mH
Holding Torque	12N-cm MIN	Detent Torque	0.5 N-cm Max.
Rotate Direction	ACBDA CW	Insulate Resistance	100Mohm(DC500V)
HI-POT	AC600V/1mA/1S	Insulation Class	Class H 180°C
Rotor Inertia	12.9 g-cm ² REF	Weight	94 g REF

A		NEW RELEASE		Xu SD	J.B.	4/24/24
REV.	ECN NO.	DESCRIPTION		MADE BY	APPR. BY	DATE
		VIEW	LDO Motors Co., Ltd.			
		SCALE	Part NO. 1.8° 36mm Round Pancake Stepper LDO-365TH22-1204AHG(RRF)			
DRAWN BY	CHECKED BY	APPR. BY	DATE	FACTORY CODE	SHEET NO.	
Xu SD	J.B.	J.B.	7/29/21		1/1	